

# The Influence Of Experiential Marketing (Sense Marketing, Feel Marketing, Think Marketing, Act Marketing) Against The Quality Of The College Of Religious Islam Negeri (Ptkin) In East Java Indonesia

---

**Submission date:** 20-Jun-2022 09:33PM (UTC+0700)  
by Asrop Safi'i

**Submission ID:** 1860174245

**File name:** 464-Article\_Text-3472-1-10-20220326.pdf (279.91K)

**Word count:** 6637

**Character count:** 34415

## The Influence Of Experiential Marketing (Sense Marketing, Feel Marketing, Think Marketing, Act Marketing) Against The Quality Of The College Of Religious Islam Negeri (Ptkin) In East Java Indonesia

Nik Haryanti<sup>1\*</sup>, Prim Masrokan Mutohar<sup>2</sup>, Mujamil Qomar<sup>3</sup>, Asrop Syafi'i<sup>4</sup>

<sup>1</sup>IAIN Pengeran Diponegoro Nganjuk, East Java, Indonesia

<sup>2,3,4</sup> UIN Satu Tulungagung, East Java, Indonesia

\*Corresponding Author:

Email: [nikharyanti1983@gmail.com](mailto:nikharyanti1983@gmail.com)

### Abstrak

The purpose of this study is to analyze the influence of the sense of marketing, feel marketing, think marketing, act marketing and relate marketing to High quality Religious Islam Negeri (PTKIN). This type of Research using mixed methods (mixed method). The population in this study is 1.304 personnel. Sample research are 200 staffs. data collection techniques are questionnaires, interviews, observation and documentation. The data analysis technique used is quantitative analysis by using SEM AMOS. The results of the research indicate that there is influence of sense marketing, feel marketing, think marketing is the act of marketing and relate marketing to High quality Religious Islam Negeri (PTKIN) in IAIN Tulungagung and UIN Malang.

**Keyword:** Sense marketing, feel marketing, think marketing, act marketing, relate marketing.

## I. INTRODUCTION

Universities as institutions of formal education, which is organized by the government expected to be able to plan and develop the learning process, so as to create a conducive learning atmosphere for the learners to achieve educational goals. The number of Universities in Indonesia increased sharply, up to the end of the year 2010 Universities in Indonesia amounted to approximately 2.960 which consists of 204 State Universities and 2.756 Private Universities. The increase in the number of Universities in Indonesia lead the competition is getting tougher. State universities (PTN) and Private Universities (PTS) compete with each other to get students. To win the competition in the world of education, all Universities should have the right business strategy in marketing services. College is not only to improve the quality and the quality of educational programs, providing all facilities offered, set a price policy, and to make the locations affordable by the target market.

Competition between Universities more attractive (Wijaya, 2018). Levels of increasingly sharp competition among the Universities both public and private universities in Indonesia requires a fundamental change to be able to compete, let alone the target to be able to take part in the global competition. The high competition in the field of higher education, in turn drive the entire business entity in the industry of higher education to as hard as possible to continuously find ways to effectively strengthen the competitive advantage of universities. The creation of a competitive advantage of a higher education is required to be able to understand the demands of customers towards the services of the education that she wanted. On the education industry shows a shift in the customers' demands is the things that will be responded to by competitors in creating competitive advantage. This condition requires all service providers to be better able to presents excellent service and be able to foster loyalty (Noegroho, et.al, 2013). To achieve the competitiveness of Higher Education, as expressed by the Ham and Hayduk that in a market that has high competition, satisfaction with services will have differences. Satisfaction possible can have an effect on what students perceived to accept or reject (Ham and Hayduk, 2003).

Universities should indeed be more active to attract input-quality. This is in order to increase competitiveness. No wonder if the choice to innovate by advancing the time of recruitment of the prospective student and the student achievement, becoming a new strategy for Universities, in the context of the marketing of the institution.

College is positioning himself as the featured Universities, the mainstay of or favorite regulated the government certainly has a bargaining position that is better. However, the trend of a mature student it turned out to not only see the positioning of the featured Universities, a mainstay and a favorite as the only consideration to decide on choosing a College at the institute. Consideration of the positioning of Universities slang and bona fide turns out to be a new phenomenon in the marketing of educational institutions. It is important to get the response of Higher Education management. Quality, the discipline but still slang tends to also be the idealism of the young. College can be trusted, with more infrastructure support, air-Conditioning, facilities, adequate technology, now is a market demands to the obligations to be executed by the College, in order to market the institution.

The most effective marketing for higher education is experiential marketing strategies. This is supported by research Reynard Olli and Nurcaya (2016), experiential marketing is a part of marketing which is assessed from the point of view of experience that is perceived by the consumer into buying a product so that the experience of the consumers can be satisfied. According to Schmitt (1999) Experiences are private events that occur in response to some stimulation (e.g., as provided by marketing effort before and after the purchase) that experience is event-personal events that occur as a response to some type of stimulus (for example given by the marketing efforts before and after the purchase). Thus experience reveal that emotion is not just a play an important role in decision-making, but also a powerful device to create loyalty. Therefore, to obtain a competitive advantage, then it should be done by applying marketing experiential. In the stages of experiential marketing the college views the customer as the figure who has the emotional value that is one view that emphasizes the relationship between the college with the customer due to the presence of an unforgettable experience by customers. An unforgettable experience is what makes the basis for doing the re-purchase by the customer.

Experiential marketing is a way to make customers create experiences through the five senses (sense), creating affective experiences (feel), creating the experience of thinking in a creative (think), creating a customer experience that is associated with the body physically, with behavior and lifestyle as well as with experiences as a result of interaction with other people (act), also create experiences that connect with a state of social, lifestyle, and culture can be reflected the brand which is a development of sensations, feelings, cognitions and actions (relate) (Schmitt, 1999). Experiential marketing is a marketing concept which aims to establish a customer-loyal customers by touching their emotions and provide a feeling that is positive for products and service (Reliable, 2010).

Competition between universities both public and private trigger the prospective students to be more rational in choosing a higher education. Efforts to meet the desires of students and prospective students is the key to success to win the competition. The best efforts made by the college is the willingness spontaneously from the students because they get satisfaction, so that automatically performs the word of mouth positive image building of the college. One way to achieve this is through experiential marketing strategies in improving the quality and competitiveness in higher education.

Strategy Experiential Marketing seeks to create a positive experience for the consumer in consuming the product or service that can be used as a reference for marketers to predict consumer behavior in the future in the form of the action re-purchase. In this case the side of emotional products developed through the efforts of marketing. Emotional experiences can be created by creating a brand that gives an unforgettable experience to their customers, with the support of the marketing programs that better. A good experience and impressive will create the onset of positive feelings and emotions towards the brand. The onset of a feeling satisfied and want to repeat the experience gained, is now widely applied by the manufacturer to the face of competition where a lot of similar products with only a slight difference in the specifications of each other.

Competition between universities, public trigger the prospective students to be more rational in choosing a higher education. Efforts to meet the desires of students and prospective students is the key to success to win the competition. One way to achieve this is through experiential marketing strategies in improving the quality and competitiveness in higher education.

Quality as an idea that dynamic, it can be used as a concept of relative (Sallis, 2010: 53). Quality has two aspects. The first is conform to the specifications, it is often concluded as in accordance with the objectives and benefits, sometimes these definitions are often named after the definition of a manufacturer about the quality, the second is to meet the needs of the customer. Basically, one of the main key to improving the quality of higher education is the commitment to change the quality of lecturers and academic quality to be proud of (Alma and Hurriyati, 2008: 24). The quality of lecturers can be seen from the scientific competence, mastery of methods of teaching, emotional control and discipline. While the academic quality can be seen from the quality of the process of human education, measurement tools, curriculum and facilities is reflected in the quality of teaching, the quality of the lesson material and the quality of learning outcomes, so that eventually formed a set of abilities.

Strategy Experiential Marketing seeks to create a positive experience for the consumer in consuming the product or service that can be used as a reference for marketers to predict consumer behavior in the future in the form of the action re-purchase. In this case the side of emotional products developed through the efforts of marketing. Emotional experiences can be created by creating a brand that gives an unforgettable experience to their customers, with the support of the marketing programs that better. A good experience and impressive will create the onset of positive feelings and emotions towards the brand. The onset of a feeling satisfied and want to repeat the experience gained, is now widely applied by the manufacturer to the face of competition where a lot of similar products with only a slight difference in the specifications of each other.

Experiential marketing strategies according to Maghnati, et.al. (2012), namely a significant positive effect of experiential marketing with the value of the experience (Experiential Value). Likewise Nigam (2012), marketing experimental focus on customer's feeling, feel, think, act and relate their experiences. The value of combined experience the benefits derived from perceptions of playfulness, aesthetics, customer returns for excellence in service. Experiential marketing is very useful for universities that want to increase brand who are at the stage of decline, differentiate their products from competitors' products, create an image and identity, increase innovation and persuade customers to try and buy the product. The most important thing is to create a loyal customer, so that the college can show the quality and can compete with other universities.

## II. METHOD

### Type Of Research

This study aims to get an overview of in-depth strategy experiential marketing to improve the competitiveness of the approach with a mix method. In this study, mixed methods (mixed method) is considered to be appropriate to help solve the problem. Mixed Method is a method that combines qualitative and quantitative approaches in terms of methodology (such as in the stage of data collection), and the study of a mixed model combining the two approaches in all stages of progress research (Tashakkori and Teddlie, 2010). Research mixed method gives the results of research is better because it has a wealth of data, because it can be integrating or combining qualitative and quantitative data. But still occurs distinction between qualitative and quantitative data, but now the two are not separated but rather combined to reinforce each other, clarify and deepen the results of the research.

Methods qualitative research is a research method used to examine the condition of the object which is natural, data collection technique is done in triangulasi (combined), the resulting data is descriptive, and data analysis is inductive. While quantitative research methods, namely an approach that emphasizes the analysis of the data numeral (numbers) are processed with statistical methods. The results of qualitative research emphasizes the significance of the generalisasi.



As according to Creswell (2014) states: mixed method Research is a research approach that combines or associate a form of qualitative and quantitative form. Accordingly a study research says the mix if integrating data, engineering, design as well quantitative and qualitative approaches in a single research. Mixed methods concurrent/at any time (concurrent mixed methods) is a study that combines quantitative data and qualitative data in one time.

The strategy of mixed methods used in this research is the order of the quantitative and qualitative analysis. the purpose of this strategy is to identify the components of the concept (subkonsep) through the analysis of quantitative data and then collecting qualitative data in order to expand the information available. The point is to unite the quantitative data and qualitative data in order to obtain the analysis is complete.

17 Qualitative method in this research is intended to describe the fact experiential marketing strategies in improving the quality of higher education and competitiveness of higher education, it is dug through observation, interview, and documentation, in order to obtain the understanding and interpretation of the depth the meaning of such facts, or informant that other supports in this study. Quantitative method in this study will produce quantitative data, this method is used to know experiential marketing, quality and competitiveness of the excavated using a questionnaire or a questionnaire with qualitative methods.

This study uses research methods kombinasi (mixed method) sequence with the use of qualitative first, then after that using quantitative methods.

#### Population and Study Sample

The population is a generalization region consisting of the objects and subjects that have a certain quantity and characteristics defined by the researchers to be studied and then drawn a conclusion. The population should be taken into account the urgency for the life of a relatively wide. In addition, it is also known populations are homogeneous and heterogeneous. The second type of grouping, will have a meaning of its own in the sampling. The population in this research is the education of IAIN Tulungagung total of 643, and UIN Malang as 661. So the population in this research is 1.304 personnel. As for the sample in this study using random sampling technique (random sample proportionally) according to the stratification, namely the taking of the sample members from the population randomly with regard to strata that exist in the population (Sugiyono, 2012). According to Hair et.al (in Suliyanto, 2011) that the sample size in accordance with the SEM is 100-200 people. Samples in quantitative research are 200 staffs in IAIN Tulungagung and UIN Malang.

#### Data Analysis techniques

Data analysis is the process of simplification of data into a form that can be more easily read and interpreted. The method used in the analysis of data is as follows:

##### 1) Test the Validity of the Factor or Test CFA (Confirmatory Factor Analysis)

4 CFA test used to reduce the indicators on the research variables. Indicators are used as a measure research variables are the indicators that have a p value < 0.05 and the loading factor is > 0.5, while the indicator which has a p value > 0.05 and loading factor of < 0.5 eliminated from the model. CFA test using the program AMOS, the test is performed 2 times, i.e. on the Exogenous variables and the Endogenous variables.

At the output of Regression Weight, on the value of P (Probability), if the value is not significant (above 0.05) then the indicator should be removed (Ghozali, 2014). And on the Standardized Regression Weight, the value of loading factor (Estimate) above 0.5 indicate such indicators can explain the existing constructs (Singgih, 2015).

##### 2) Hypothesis Testing

Analysis of the SEM model consists of several stages, among others:

##### 16 The Development of Theoretical Models

Based on the hypothesis that was built in this research, then the research model that will be analyzed further with the analysis of SEM is as follows:

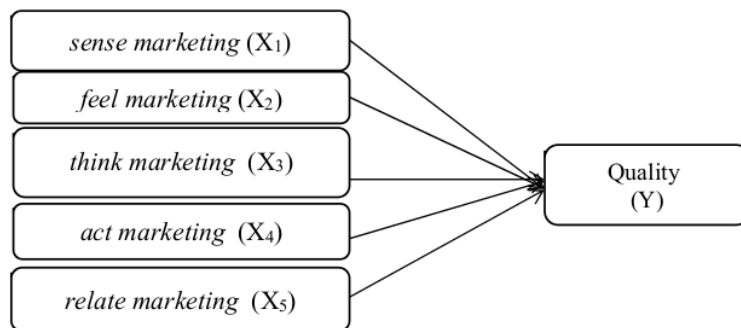

**Fig 1.** Pictures Of Theoretical Models

Description:

X1 : *Sense marketing* (X1) (Independent variable = *Independen*)

X2 : *Think marketing* (X2) (Independent variable = *Independen*)

X3 : *Feel marketing* (X3) (Independent variable = *Independen*)

X4 : *Act marketing* (X4) (Independent variable = *Independen*)

X5 : *Relate marketing* (X5) (Independent variable = *Independen*)

Y2 : Competitiveness (variabel terikat = *dependen*)

By observing the path of the diagram above, there are two constructs are different, namely exogenous constructs and construct endogenous. Exogenous constructs (exogenous construct) is the independent variables that are not predicted by other variables in the model. In the diagram to be exogenous constructs is the *sense of marketing, feel marketing, think marketing, act marketing, and relate marketing*. While the construct of endogenous (endogenous construct) are the factors that predicted by one or several of the constructs. In this study, the constructs are endogenous quality.

8 a) The Development of the SEM Model

In this second step, the theoretical models that have been built in the first phase will be described in a diagram of the SEM model that will make it easier to see the relationship causal relationship to be tested. In this diagram, the relationship between constructs will be expressed through the arrows. Arrow straight show a causal relationship is directly between one konstruk with konstruk other. While the line-curved lines between konstruk with arrows on each end show the correlation between konstruk.

b) Test the Assumptions of the Model

The assumptions that must be met in testing the SEM model is as follows:

(1) Normality Test Data

One of the assumptions of the use of parametric statistics is the assumption of multivariate normality. Normality test is done to see the level of normality of the data used, whether the data is normally distributed or not. Normal failure distribution of the data can be seen from the value of the critical ratio (CR) on the skewness and kurtosis. Figure comparison of the CR is the number Z. In general, use a confidence level of 99%, the confidence level is the level of significance is 0.01 or 1% obtained a number Z is 2,58. Thus a distribution of data is said to be normal if the numbers cr skewness or numbers cr kurtosis among -2,58 up to 2,58. However, if the numbers are there below -2,58 (e.g. -4, -5 etc) or above 2,58, the distribution of the data can be said to be not normal (Singih, 2015).

c) Test of Goodness of fit (Feasibility Test Model) 4

Test of Goodness of fit is used to determine how precise the manifest variables (indicator variables) that can explain the latent variables (constructs) that exist.

10 d) Hypothesis Testing

After overall, a structural model can be considered fit, the next process is to see whether there is a significant influence between the independent variables with the dependent variable. Hypothesis testing is done by looking at the results of the estimation of the research model (output Regression Weight).

**III. RESULT**

1. Uji CFA (*Confirmatory Factor Analysis*) or Test Construct Validity

CFA test or uji the validity of the construct, is intended to determine whether each indicator can explain the existing constructs. Indicators are used as a measure research variables are the indicators that have a p value < 0.05 and the loading factor is > 0.4 while the indicator which has a p value > 0.05 and loading factor of < 0.5 eliminated from the model. A significance value (P value) if more than 0.05, then the indicator at the drop of a model, a second look at the value of the standardized loading factor (the value of the Estimate), if the under is 0.50, then the indicator at the drop because it is not considered a valid measure of the constructs of the latent.

1) CFA Test on the exogenous variables

Model exogenous variables in this study consist of 1 variable is the Quality of the product. Here is a model of the exogenous variables:

**Fig 2 . Image Model Exogenous Variables**

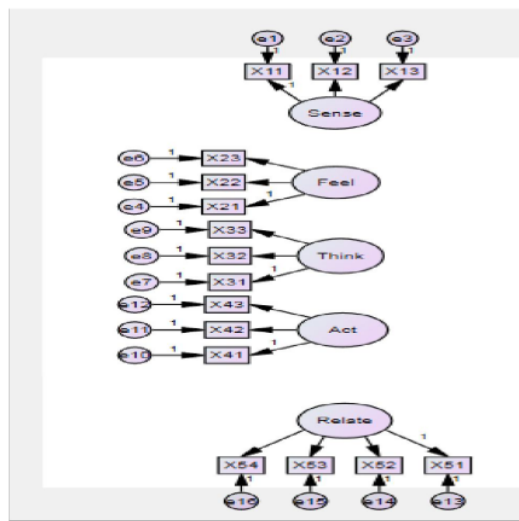

The results of the CFA test (*Confirmatory Factor Analysis*):

**Table 1.** The test results of the CFA on the exogenous variables  
**Maximum Likelihood Estimates Regression Weights: (Group number 1 - Default model)**

			Estimate	S.E.	C.R.	P
X11	<---	Sense	1.000			
X12	<---	Sense	1.307	.199	6.559	***
X13	<---	Sense	1.635	.251	6.508	***
X21	<---	Feel	1.000			
X22	<---	Feel	1.625	.449	3.615	***
X23	<---	Feel	.753	.156	4.834	***
X31	<---	Think	1.000			
X32	<---	Think	1.290	.237	5.453	***
X33	<---	Think	.779	.140	5.543	***
X41	<---	Act	1.000			
X42	<---	Act	.924	.157	5.887	***
X43	<---	Act	.710	.114	6.230	***

	Estimate	S.E.	C.R.	P
X51 <--- Relate	1.000			
X52 <--- Relate	1.568	.168	9.351	***
X53 <--- Relate	1.273	.147	8.691	***
X54 <--- Relate	1.205	.145	8.301	***

At the output of Regression Weight, on the value of P (Probability), if the value is not significant (above 0.05) then the indicator should be removed. Looks probability value are all showing signs \*\*\* means significant at the level of 0.000 which means also less than 0.05, with this if seen from the Regression Weight then valid indicator all, but the significant result is not necessarily provide a loading factor (the value of the Estimate) is high (above 0.5).

**Table 2. Standardized Regression Weights: (Group number 1 - Default model)**

	Estimate
X11 <--- Sense	.609
X12 <--- Sense	.727
X13 <--- Sense	.748
X21 <--- Feel	.490
X22 <--- Feel	.878
X23 <--- Feel	.477
X31 <--- Think	.681
X32 <--- Think	.729
X33 <--- Think	.552
X41 <--- Act	.647
X42 <--- Act	.820
X43 <--- Act	.572
X51 <--- Relate	.655
X52 <--- Relate	.813
X53 <--- Relate	.807
X54 <--- Relate	.737

The Standardized Regression Weight, the value of loading factor (Estimate) above 0.5 indicate such indicators can explain the existing constructs. Can be seen there are all valid items, this is because the value of the estimate is more than 0.5. This shows the indicators can explain the existing constructs.

1) CFA Test on endogenous variables

Model endogenous variables in this study consisted of 1 the dependent variable is the quality. Here is a model of endogenous variables:

**Fig 3. A Picture Of The Model Endogenous Variables**

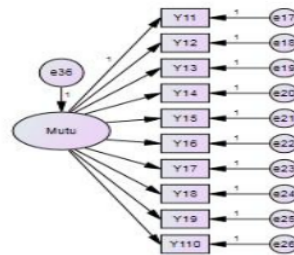

Hasil uji CFA (*Confirmatory Factor Analysis*):



**11** **Table 3.** The test results of the CFA on the endogenous variables  
**Maximum Likelihood Estimates Regression Weights: (Group number 1 - Default model)**

			Estimate	S.E.	C.R.	P
Y11	<---	Mutu	1.000			
Y12	<---	Mutu	.853	.059	14.579	***
Y13	<---	Mutu	.610	.054	11.291	***
Y14	<---	Mutu	.531	.055	9.673	***
Y15	<---	Mutu	.688	.062	11.079	***
Y16	<---	Mutu	.708	.064	11.142	***
Y17	<---	Mutu	.566	.058	9.766	***
Y18	<---	Mutu	.455	.053	8.612	***
Y19	<---	Mutu	.374	.051	7.311	***
Y110	<---	Mutu	.458	.058	7.858	***

At the output of Regression Weight, on the value of P (Probability), if the value is not significant (above 0.05) then the indicator should be removed. Looks probability value are all showing signs \*\*\* means significant at the level of 0.001, which means also less than 0.05, with this if seen from the Regression Weight then valid indicator all, but the significant result is not necessarily provide a loading factor (the value of the Estimate) is high (above 0.5).

**Table 4.** The test results of the CFA on the endogenous variables  
**Standardized Regression Weights: (Group number 1 - Default model)**

			Estimate
Y11	<---	Mutu	.818
Y12	<---	Mutu	.851
Y13	<---	Mutu	.709
Y14	<---	Mutu	.629
Y15	<---	Mutu	.701
Y16	<---	Mutu	.704
Y17	<---	Mutu	.635
Y18	<---	Mutu	.573
Y19	<---	Mutu	.501
Y110	<---	Mutu	.534

The Standardized Regression Weight, the value of loading factor (Estimate) above 0.5 indicates indicator is declared invalid because the value of the estimate is more than 0.5. Then carried out the removal of the indicator.

#### b. Test The Assumptions Of The Model

The assumptions that must be met in testing the model the analysis of the SEM is as follows:

##### 1) Test The Normality Of The Multivariate

Estimation by the method of Maximum Likelihood (ML), the existence of the assumptions that must be met, namely the distribution of the observed variable is normal for multivariate. The evaluation of the normality of multivariate done by using the criteria of the critical ratio (cr) of the multivariate on kurtosis, if in the range of -2,58 up to 2,58 mean normal distribution of data in the multivariate. Here are the results of the normality test of the data on the model:

**11** **Table 5.** The Results Of Normality Test Assessment of normality (Group number 1)

Variable	min	max	skew	c.r.	kurtosis	c.r.
Y110	1.000	4.000	.034	.194	-.524	-1.513
Y19	1.000	4.000	.161	.928	.517	1.491

<http://ijstm.inarah.co.id>

Variable	min	max	skew	c.r.	kurtosis	c.r.
Y18	1.000	4.000	.033	.191	-.692	-1.999
Y17	1.000	4.000	.009	.054	-.454	-1.310
Y16	1.000	4.000	.036	.206	-.092	-.265
Y15	1.000	4.000	.322	1.861	.502	1.450
Y14	1.000	4.000	.154	.891	-.113	-.325
Y13	1.000	4.000	.106	.611	.450	1.299
Y12	1.000	4.000	.222	1.284	.131	.378
Y11	1.000	4.000	.419	2.420	.104	.301
X54	1.000	4.000	-.842	-4.859	-.163	-.471
X53	1.000	4.000	-.874	-5.049	-.376	-1.085
X52	1.000	4.000	-.832	-4.802	-.584	-1.685
X51	1.000	4.000	-.902	-5.205	.251	.723
X43	1.000	4.000	-.733	-4.231	.161	.465
X42	1.000	4.000	-1.264	-7.296	1.481	4.274
X41	1.000	4.000	-.894	-5.161	-.222	-.641
X33	2.000	4.000	-.334	-1.926	-.761	-2.196
X32	1.000	4.000	-.813	-4.695	.028	.080
X31	1.000	4.000	-.950	-5.486	1.103	3.183
X23	1.000	4.000	-.750	-4.331	.555	1.603
X22	1.000	4.000	-.648	-3.740	-.096	-.277
X21	1.000	4.000	-.812	-4.687	.162	.466
X13	1.000	4.000	-.921	-5.315	-.213	-.615
X12	1.000	4.000	-.721	-4.162	.023	.066
X11	1.000	4.000	-.843	-4.864	.975	2.815
Multivariate					120.284	24.076

Source: Data processed, 2019

Based on the output above, it looks overall (multivariate) distribution of normal data, because the number of multivariate much is in under 2,58.

Testing the normality of data was done by observing the value of CR in multivariate. If the value of the critical ratio for multivariate within in the hose -2.58 up to 2.58, then it can be categorized as a normal data distribution. Based on the results of data processing known the value of CR multivariate amounted to 120.284 outside hose -2.58 up to 2.58. Thus, it is concluded that the assumption of multivariate normality is not yet fulfilled. Although in the calculation of the results of the analysis concluded thus, the argument of the Central Limit (Limit Central Theorem) states that the assumption of normality is not too critical for the large sample (Solimun, 2002).

3. Uji Goodness of fit (The Feasibility Test Model)

At this stage of the testing performed on the suitability of the model against a variety of criteria. The following table of assessment criteria Goodness of fit and the results:

Tabel 6. Hasil uji Goodness of fit

Goodness of Fit	Cut off value	Hasil	Keputusan
Probabilitas Chi Square	≥ 0,05	0,000	Bad Fit
CMIN/DF	≤ 2,00	9,689	Bad Fit
GFI	≥ 0,90	0,544	Bad Fit
AGFI	≥ 0,90	0,446	Bad Fit
CFI	≥ 0,90	0,504	Bad Fit
TLI	≥ 0,90	0,408	Bad Fit
NFI	≥ 0,90	0,445	Bad Fit
IFI	≥ 0,90	0,507	Marginal Fit
RMSEA	≤ 0,08	0,209	Bad Fit

RMR	$\leq 0,05$	0,246	Bad Fit
-----	-------------	-------	---------

Source: Data processed, 2019

From the output above can be seen the value of the indicator not meet the Good fit of at least 5 indicators. So overall model could not be said to fit, with this it will be a modification of the model. Modifications to the model done by connecting each other with a line or mengkovariankan between the variables of the error on the model, in accordance with that recommended by AMOS (at the output of Modification Indices).

The results of the test of Goodness of fit after modification of the model presented in the following table:

**Table 7.** Test results Goodness of fit setelah modifikasi model

Goodness of Fit	Cut off value	Hasil	Keputusan
Probabilitas Chi Square	$\geq 0,05$	0,000	Bad Fit
CMIN/DF	$\leq 2,00$	1,468	Good Fit
GFI	$\geq 0,90$	0,828	Marginal Fit
AGFI	$\geq 0,90$	0,775	Bad Fit
CFI	$\geq 0,90$	0,937	Good Fit
TLI	$\geq 0,90$	0,926	Good Fit
NFI	$\geq 0,90$	0,830	Marginal Fit
IFI	$\geq 0,90$	0,939	Good Fit
RMSEA	$\leq 0,08$	0,069	Good Fit
RMR	$\leq 0,05$	0,039	Good Fit

Source: Data processed, 2019

Based on the above table, it can be seen there are already at least 5 indicators of a Good fit, it can be concluded that the overall model has been fit.

#### 4. Hypothesis Test Model

Hypothesis testing is done by looking at the results of the estimation of the research model.

Furthermore, the researchers would like to see the significance between variables, the following is a table of significance between variables as follows:

**Table 8.** The Test results of the Influence between Variables

	Estimate	S.E.	C.R.	P
Mutu <--- Sense	.869	.125	6.936	***
Mutu <--- Think	.061	.026	2.355	.019
Mutu <--- Feel	.386	.053	7.327	***
Mutu <--- Act	.072	.017	4.334	***
Mutu <--- Relate	.118	.025	4.765	***

Based on the hypothesis testing can be concluded that the results of this study showed: there is the influence of the sense of marketing on the quality of Higher Education Religious Islam Negeri (PTKIN) in IAIN Tulungagung and UIN Malang. This is because the Probability value is more than 0.05 ( $0,000 > 0,05$ ), there is the influence of the feel of marketing on the quality of Higher Education Religious Islam Negeri (PTKIN) in IAIN Tulungagung and UIN Malang. This is because the Probability value is more than 0.05 ( $0,019 > 0,05$ ), there is the influence of the think marketing on the quality of Higher Education Religious Islam Negeri (PTKIN) in IAIN Tulungagung and UIN Malang. This is because the Probability value is less than 0.05 ( $0,000 < 0,05$ ), there is the influence of the act of marketing on the quality of Higher Education Religious Islam Negeri (PTKIN) in IAIN Tulungagung and UIN Malang. This is because the Probability value is less than 0.05 ( $0,000 < 0,05$ ) and no effect relate marketing to quality Higher Education Religious Islam Negeri (PTKIN) in IAIN Tulungagung and UIN Malang. This is because the Probability value is less than 0.05 ( $0,000 < 0,05$ ).

#### IV. DISCUSSION

The results of this study show that the Sense of marketing influence on quality of Higher Education Religious Islam Negeri (PTKIN) in IAIN Tulungagung and UIN Malang. Schmitt (1999) stated Sense is the type of experience which is the aspects of intangibles that can be felt from a product that can be captured by the five human senses, including sight, sound smell, taste and touch that will appear to create the experience. Sense marketing as a message delivered at the customers about a product or service that is perceived based on their common sense. Through the experience of Sense, customers will be able to develop the experience of logic and then they can use the experience logical to form a judgment of personal value to distinguish the products and services received (Maghnati et al, 2012). The results of this study supported with Prashalini Naidu, Nor Emmy Shuhada Derani (2016), the research shows that the dimensions that affect the university, namely the quality of this university. Sense marketing can improve the quality, quality is "a thing that is associated with passion and self-esteem". Thus the higher the sense of marketing through one of the interesting things of the five senses, the higher the quality of higher education.

Feel marketing affect the quality of Higher Education Religious Islam Negeri (PTKIN) in IAIN Tulungagung and UIN Malang. Feel is an attention-the attention of the little present on the consumer with the aim to touch the emotions of the customer with the incredible. Feel marketing as the experience that comes from emotions, mood, and the inner feelings of the customers for consuming products and services. Strong emotions and positive in the experience Feel will positively affect the customer relationship with the company thus, to improve the customer relationship between the customer and the seller, the company shall give the experience Feel strong and positive.

Feel marketing is one of the important part in experiential marketing strategies, where the feel can be done with satisfactory services with friendliness and courtesy of the employees, timely service, and a sympathetic attitude. According To Jarome S. Arcaro (2006: 75) asserts that quality is a structured process to improve the output that is produced. Quality is not a magical object or something that complicated, the quality is based on common sense. Thus show that the higher the feel of marketing, the higher the quality of higher education.

Think marketing has no effect on the quality of Higher Education Religious Islam Negeri (PTKIN) in IAIN Tulungagung and UIN Malang. According to Jarome (2006: 77), while talking about the problem of improvement of quality of education, it is often spoken of is the improvement of the ranking of the increase in class or grades. In college who type like that, the responsibility for the improvement of the quality of education is much there is on the lecturer. Thus show that the higher the think marketing, the higher the quality of higher education.

Act marketing affect the quality of Higher Education Religious Islam Negeri (PTKIN) in IAIN Tulungagung and UIN Malang. Act is a way to reflect to the customer a alternative to others to do something, change the style of life and social interaction. Experience that allows consumers to develop the experience associated with the physical body, their behavior and lifestyle, as well as experience gained from social interaction with other people. Through the experience of the Act, the consumer makes it possible to develop taste sensations, making the connection with the products or services offered. Thus show that the higher the act of marketing, the higher the quality of higher education.

Relate marketing affect the quality of Higher Education Religious Islam Negeri (PTKIN) in IAIN Tulungagung and UIN Malang. Relate marketing contains aspects of sense, feel, think, act marketing as well as focuses on the creation of a positive perception in eyes of customers. Relate connects customers individually with the community, or culture. In general, relate experience shows the relationship with other people, other groups (e.g., job, lifestyle) or community of broader social and abstract (for example the state, society, culture). The purpose of relate is to connect the consumer with the cultural and social environment, as reflected by the brand of a product. College can create a relate between its customers with direct contact either phone or physical contact, accepted to be one part in a group or to become a member so as to make consumers to be happy or not to hesitate to come back. Conversely, if it does not happen within the meaning



of the consumer feel neglected, then the consumer will think twice to come back. Thus show that the higher relate marketing, the higher the quality of higher education.

## REFERENCE

- [1] Alma, Buchari dan Ratih Hurriyati, (2008) *Manajemen Corporate dan Strategi Pemasaran Jasa Pendidikan*, Bandung: Alfabeta, 2008
- [2] Andreani, Fransisca (2007) “Experiential Marketing (Sebuah Pendekatan Pemasaran)”, *Jurnal Manajemen Pemasaran*, Vol. 2, No. 1.
- [3] Arcaro, Jerome S. (2006), *Pendidikan Berbasis Mutu*, Jogjakarta: Pustaka Pelajar.
- [4] Armistead, Gellin G. (1999) *Customer Service and Support*, Jakarta: PT Gramedia
- [5] Creswell, John W. (2014) *Research Design; Pendekatan Kualitatif, Kuantitatif dan Mixed*, Yogyakarta: Pustaka Pelajar
- [6] Ghozali, Imam. (2014) *Konsep dan Aplikasi Dengan Program AMOS 22*, Semarang: Badan Penerbit Universitas Diponegoro
- [7] Ham, L dan S. Hayduk, (2003) *Gaining Competitive Advantages in Higher Education: Analyzing the Gap between Expectations and Perceptions of Service Quality*, *International Journal of Value-Based Management*, Vol 16. No. 13
- [8] Handal, Nehemia S. (2010) *Analisis Pengaruh Experiential Marketing Terhadap Loyalitas*. *Jurnal Manajemen Universitas Diponegoro*.
- [9] Indriani, Farida (2006) “Experiential Marketing sebagai Suatu Strategi dalam Menciptakan Customer Satisfaction dan Repeat Buying Untuk Meningkatkan Kinerja Pemasaran”, *Jurnal Studi Manajemen & Organisasi*, Volume 3, Nomor 1
- [10] Kuncoro, Mudrajad. (2007) *Ekonomika Industri Indonesia: Menuju Negara Industri Baru 2030?'*. Yogyakarta: Andi
- [11] Maghnati, Farshad et.al. (2012) *Exploring the Relationship between Experiential Marketing and Experiential Value in the Smartphone Industry*, *Jurnal International Business Research*; Vol. 5, No. 11
- [12] Muhandi, (2017) *Strategi Operasi untuk Keunggulan Bersaing*, Jakarta: Graha Ilmu
- [13] Muhandi, (2017), *Strategi Operasi untuk Keunggulan Bersaing*, Jakarta: Graha Ilmu
- [14] Nigam, Ashutosh. ( 2012), *Modeling Relationship between Experiential Marketing, Experiential Value and Purchase Intension in Organized Quick Service Chain Restaurants Using Structural Equation Modeling Approach*, *IJCSMS International Journal of Computer Science & Management Studies, Special Issue* of Vol. 12
- [15] Noegroho, Oddy Adam. et.all, (2013) *Pengaruh Experiential Marketing Dan Brand Trust Terhadap Kepuasan Pelanggan Dan Loyalitas Pelanggan*, *Jurnal Administrasi Bisnis (JAB)* | Vol. 6 No. 2
- [16] Peraturan Menteri Pendidikan Nasional No. 41 Tahun 2007 tentang standar proses
- [17] Pham, Thi Hoa dan Ying-Yuh Huang. (2015) The Impact Of Experiential Marketing On Customer’s Experiential Value And Satisfaction: An Empirical Study In Vietnam Hotel Sector, *Journal of Business Management & Social Sciences Research (JBM&SSR) Volume* 4, No.1
- [18] Prashalini Naidu, Nor Emmy Shuhada Derani, ( 2016 )Jurnal. A Comparative Study on Quality of Education Received by Students of Private Universities versus Public Universities, *Procedia Economics and Finance* 35
- Reynard Ollii, Kevin Reno dan Nyoman Nurcaya, (2016) “Peran Kepuasan Pelanggan dalam Memediasi Pengaruh *Experiential Marketing* terhadap Pembelian Ulang Tiket Pesawat pada PT Jasa Nusa Wisata Denpasar”, *E-Jurnal Manajemen Unud*, Vol. 5, No.8
- [19] Sallis, Edward (2010), *Manajemen Mutu Terpadu Pendidikan*, Yogyakarta: IRCiSoD
- [20] Schmitt, Bernd H. (1999), *Experiential Marketing*, The Fress Press: New York
- [21] Singgih, Santoso, (2015) *AMOS 22 untuk Structural Equation Modelling*, Jakarta: PT Elex Media Komputindo
- [22] Sugiyono, (2012) *Metode Penelitian Pendidikan Pendekatan Kuantitatif, Kualitatif, dan R&D*, (Bandung: Alfabeta 2012
- [23] Suliyanto. (2011) *Ekonometrika Terapan: Teori dan Aplikasi dengan SPSS*. Yogyakarta: ANDI
- [24] Tashakkori, Abbas & Charles Teddlie, (2010) *Mixed Methodology*, Jogjakarta: Pustaka Pelajar
- [25] Wijaya D. (2008) *Pemasaran Jasa Pendidikan Sebagai Upaya untuk Meningkatkan Daya Saing Sekolah*. *Jurnal Pendidikan Penabur*, Tahun ke 7, No. 11, dalam <http://www.bpkpenabur.or.id>,

# The Influence Of Experiential Marketing (Sense Marketing, Feel Marketing, Think Marketing, Act Marketing) Against The Quality Of The College Of Religious Islam Negeri (Ptkin) In East Java Indonesia

## ORIGINALITY REPORT

15%

SIMILARITY INDEX

12%

INTERNET SOURCES

5%

PUBLICATIONS

7%

STUDENT PAPERS

## PRIMARY SOURCES

1	<a href="http://ejournal.umm.ac.id">ejournal.umm.ac.id</a> Internet Source	2%
2	<a href="http://www.semanticscholar.org">www.semanticscholar.org</a> Internet Source	1%
3	Submitted to Chester College of Higher Education Student Paper	1%
4	<a href="http://scholarsmepub.com">scholarsmepub.com</a> Internet Source	1%
5	<a href="http://eprints.ukmc.ac.id">eprints.ukmc.ac.id</a> Internet Source	1%
6	Submitted to Universitas Muria Kudus Student Paper	1%
7	<a href="http://ijstm.inarah.co.id">ijstm.inarah.co.id</a> Internet Source	1%
8	Submitted to Universitas Terbuka Student Paper	1%

---

9	<a href="http://www.iiste.org">www.iiste.org</a> Internet Source	1 %
10	<a href="http://d.researchbib.com">d.researchbib.com</a> Internet Source	1 %
11	<a href="http://es.scribd.com">es.scribd.com</a> Internet Source	1 %
12	<a href="http://eprints.unmer.ac.id">eprints.unmer.ac.id</a> Internet Source	1 %
13	<a href="http://ejournal.unsrat.ac.id">ejournal.unsrat.ac.id</a> Internet Source	1 %
14	<a href="http://isclo.telkomuniversity.ac.id">isclo.telkomuniversity.ac.id</a> Internet Source	1 %
15	Nabila Aufa Nadya. "EFFECT OF EXPERIENTIAL MARKETING ON CUSTOMER LOYALTY: THE ROLE OF CUSTOMER SATISFACTION AS A MEDIATOR", Journal of Business Studies and Mangement Review, 2020 Publication	1 %
16	<a href="http://www.ijbmm.com">www.ijbmm.com</a> Internet Source	1 %
17	<a href="http://ejournal.staim-tulungagung.ac.id">ejournal.staim-tulungagung.ac.id</a> Internet Source	1 %

---

Exclude quotes On

Exclude bibliography On

Exclude matches < 1%